



**3 GHz TNC LATCHING S.P.D.T. SWITCH**

OPTIONS: INDICATOR / TTL DRIVE

**R F CHARACTERISTICS**

FREQUENCY RANGE : 0 - 3 GHz  
 IMPEDANCE : 50 Ohms

FREQUENCY (GHz)	0 - 1	1 - 2	2 - 3
V.S.W.R <=	1.15	1.20	1.25
INSERT. LOSS <=	0.15 dB	0.20 dB	0.25 dB
ISOLATION >=	85 dB	80 dB	75 dB
AVER. POWER (*)	700 W	500 W	400 W

**ELECTRICAL CHARACTERISTICS**

ACTUATOR : LATCHING  
 NOMINAL CURRENT AT 25° C (±10%) : 320 mA  
 ACTUATOR VOLTAGE (Vcc) : 12V (10.2 to 13V) /NEGATIVE COMMON  
 TERMINALS : solder pins (250 Deg.C max./30 sec)  
 INDICATOR RATING : 1 W / 30 V / 100 mA  
 TTL INPUTS (E) - High level : 2.2 to 5.5V / 800µA at 5V  
 - Low level : 0 to 0.8V / 20µA at 0.8V

**MECHANICAL CHARACTERISTICS**

CONNECTORS : TNC fem. per MIL C 39012  
 LIFE : 1.000.000 cycles  
 SWITCHING TIME (nominal voltage;25° C) : < 15 ms  
 CONSTRUCTION : splashproof  
 WEIGHT : < 185 g

**ENVIRONMENTAL CHARACTERISTICS**

OPERATING TEMPERATURE RANGE (°C) : -40 , +85  
 STORAGE TEMPERATURE RANGE (°C) : -55 , +85

(\* : average power at 25° C)

4112-9212 This information is given as an indication. In the continual goal to improve our products, we reserve the right to make any modifications judged necessary

**DRAWING**

General tolerance: ± 0,5 mm

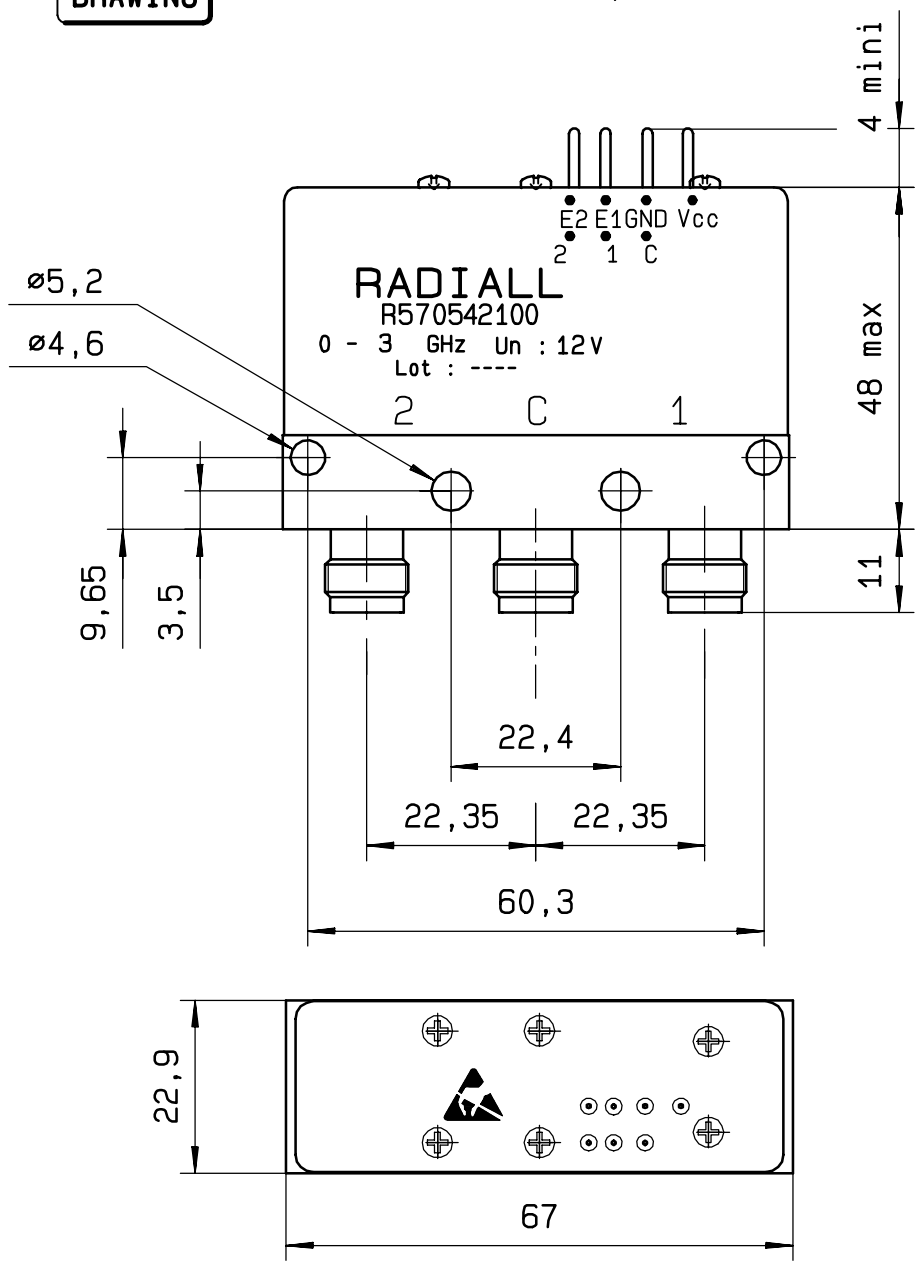

**SCHEMATIC DIAGRAM**

TTL input	RF continuity	Indicator
E1=1   E2=0	C ↔ 1	C . 1
E1=0   E2=1	C ↔ 2	C . 2
E1=0   E2=0	Memory	—
E1=1   E2=1	Forbidden	—

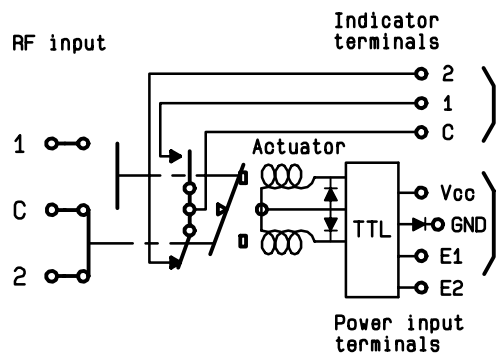

4113-9212 This information is given as an indication. In the continual goal to improve our products, we reserve the right to make any modifications judged necessary